

The ECHO



Newsletter of the
Grand Canyon State Chapter
Studebaker Drivers Club

Volume 47 Issue 6

June 2019

Inside This Issue

Officers and Board	2
State of the Chapter	3
Who's Who	3
On The Road	3
Liberty Wildlife	4
Upcoming Events	5, 6
Flag Etiquette	6
2020 Report	7
Birthdays, Anniversaries ...	7
Fabulous 4th Invitation ...	8
Thank you for Donation ...	8
Tech Tip - Bolts	8
A Brief History of Disc Brakes	9
ECHO Advertisers	10
Classifieds	11



The Stewart

Formerly
Stewart Motors,
a Studebaker dealership,
The Stewart in
downtown Phoenix held
its Grand Opening
May 22, 2019.

On display during the
festivities were two

Chapter member's Studebakers - Patrick and Brischell Eastburn's
1951 Champion and Garry Klinger's 1952 Commander SLC.

See page 3 for an article about the event.



Graphic on wall of garage.

From the Editor's Pen.....

Please note there is another new advertiser on page 10, J & R Automotive Specialists at 27th Ave. & Northern, Phoenix. As with the new advertiser last month, J & R will work on older vehicles including your Studebaker. Thanks to Peggy Eastburn for soliciting these two businesses to advertise their services. Please check the business who advertise if you are in need of services they offer.

Your editor is pleased to tell you the GCSC newsletter received a Honorable Mention in the Golden Quill competition sponsored by *Old Cars Weekly* (OCW). Other Studebaker related publications received the Golden Quill including *Turning Wheels*, *Studebaker Spokesman* (Wisconsin Region Chapter), *Steering Wheel Magazine* (Gateway Chapter) and *Avanti Magazine*. Also receiving Honorable Mention was the *Egbert Express* (NE Michigan Chapter). Thanks to OCW for the acknowledgement and to Chapter members for their contributions to *The ECHO*.

The "Studebaker Cool - 114 Years of Innovation" exhibit at the AACA Museum in Hershey, Penn. attracted 54 Studebaker vehicles for the display. Two members of the Keystone Region Chapter were the guest curators who lined up the entrants. The Chapter, along with the Studebaker National Foundation, Antique Studebaker

Club, Studebaker Drivers Club and the AAOA Inc. made donations to host the opening ceremony on May 18. "Studebaker Cool" continues through October 20th and if you are in the area this summer, be sure to stop in.

Thanks to this month's contributors - Keith Graham, Michell Eastburn, Larry Vahe, Scott Grainger (Fabulous 4th information), Studebaker Mike, Garry Klinger and Peggy Eastburn.

Chris



NEW MEMBER CHALLENGE

When A Chapter member recruits a new member to join SDC and/or the GCS Chapter, he/she will have Chapter dues paid for 2019. Just ask the new member to mention your name on the application where it asks "Referred By".

If you need recruiting materials, please contact the editor.

The Chapter is in need of someone to take care of the website. Please contact Michell if you are interested.

The ECHO is the official newsletter of the Grand Canyon State Chapter, SDC and is published 11 times per year. Contributions are welcome and encouraged. Please submit articles, tech tips, etc. by the 20th of the month preceding publication. Other newsletter editors are welcome to use any material with proper credit given.

GRAND CANYON STATE CHAPTER OFFICERS AND BOARD 2010

President

Michell Eastburn
6314 W. Fillmore St.
Phoenix, AZ 85043
602-803-1359
michell.eastburn@asu.edu

Vice President

Peggy Eastburn
6314 W. Fillmore St.
Phoenix, AZ 85043
623-936-6116
peggyeastburn@hotmail.com

Secretary

Richard Dormois
PO Box 596
Mesa, AZ 85211
702-461-3679
1938studeman@earthlink.net

Treasurer

John Rodhouse
1816 N. Dakota St.
Chandler, AZ 85251
480-244-3763
jrodhou@hotmail.com

Board Members

Richie Fein
1437 W. Rosemonte Drive
Phoenix, AZ 85027
602-499-5363
richiefein@aol.com

Brian Millette
41633 N. Emerald Lake Dr.
Anthem, AZ 85086
602-300-5313
abmillette@cox.net

Joan Painter
14395 Maria de Fortuna
Yuma, AZ 85367
928-580-4565
henj719@aol.com

ECHO Editor/Membership

Chris Collins
2410 W. Freeway Lane
Phoenix, AZ 85021
602-995-2146
ccollinsaz@cox.net

Chapter Historian: Peggy Eastburn 623-936-6116 peggyeastburn@hotmail.com

Membership: Richie Fein 602-499-5363 richiefein@aol.com

Webmaster: Position available. Contact Michell if interested. Chapter Website: <http://www.grandcanyonsdc.com>

Facebook: Studebakers Grand Canyon State Chapter Administrators: Ed Smith, Linda Smith

Pacific Southwest Zone

Regional Manager/Ariz.	Chris Collins	2410 W. Freeway Ln., Phoenix, AZ 85021	ccollinsaz@cox.net
Zone Coordinator	Bob Miles	6838 E. Miami St., Tucson, AZ 85715	rnc61coupe@aol.com
National Director	Malcolm Stinson	1794 Turkey Lake Rd., Show Low, AZ 85901	swstudebaker@live.com

SDC National Officers 2017-2019

President	Tom Curtis	3538 Gordon Rd., Elkhart, IN 46516	tomnancurtis@aol.com
Vice President	Don Jones	PO Box 229, Concord, VA 24538	keydetsdj@aol.com
Secretary	Cindy Foust	143 Studebaker Rd., Spring Mills, PA 16875	cid1966@verizon.net
Treasurer	Jane Stinson	5800 Stanley Rd., Columbiaville, MI 48421	jestinson@aol.com

STATE OF THE CHAPTER

By Michell Eastburn, President

Thank you all for your continued participation at chapter events and non-chapter events. Last month offered some awesome local scenery at Liberty Wildlife; thank you to all that attended and drove your Studebaker. The most awesome part of this event was that nearly every participating member drove a Studebaker, and a nice display of eight Studebakers adorned the side of Elwood Street for all to see.



I am excited for June as I hope members will enjoy the 'oohs' and 'ahhs' of Streetside Classics and enjoy some early morning camaraderie including coffee and bagels. Please plan on bringing out your Studebaker for the a.m. festivities and enjoy the indoor garage (yes, it should be cool inside) of approximately 200 different vehicles of various makes and models...quite possible you might even drive something else home other than a Stude.

Helpful tips and reminders for traveling across town and/or across country: *It's very easy to become complacent when traveling around town in newer vehicles and with roadside assistance, but we must all remember that we and/or a friend can be anywhere, anytime and need roadside help. A few things that might be nice to keep in your everyday driver and your Studebaker: a tire gauge, jumper cables, flashlight and extra batteries, duct tape, tow strap or tow rope, utility knife, rain poncho, funnel, drinking water, snacks, a blanket/towel, flares and gloves.*

THE STEWART

By Michell Eastburn

On May 22nd the unveiling of 'The Stewart' (new 19 story luxury apartment complex) was beautified with a display of two Studebakers in the front window of the former Stewart Motors dealership in downtown Phoenix on Central Avenue and McKinley Street.

History with Stewart Motors started back in the late 1940s when the father of our very own founding member, Bill Eastburn, worked for Stewart Motors. Since history with the dealership runs deep here in the valley of the sun, Bill was asked if he would like to present his Studebaker(s) for a display.

Thinking back to when Stewart Motors sold Studebakers in the showroom, Bill found two Studebakers that worked perfectly to join the festivities. Patrick Eastburn with his 1951 Champion and Garry Klinger with his 1952 Starlight Commander were able to display Studebakers for the very last time on the turn table of the Stewart Motors showroom. "It's been a long time since Studebakers were in that showroom window, and it won't happen again. Lucky to own one of the last to appear", Garry said about his experience to show his Commander named 'Goose'.

WHO'S WHO

This month's 'who's who' is Garry Klinger of Tempe, Arizona. Born and raised as a 2nd generation Arizonan, Garry has lived in Phoenix, Prescott, and Tempe. Garry spent several years in the wholesale paper industry and then retired from W.L. Gore & Associates after 22+ years working in their Medical Products Division. He said that the best part of his last job was being able to travel the world: Europe, Australia, Hong Kong, Singapore and Japan. "Love Japan, great people and amazing food."



Garry 'blames' his love of Studebakers on his brother after being intrigued by a spin in his 1964 GT Hawk. Garry purchased his first Studebaker, a 1955 Speedster, that he drove a whopping 5 miles and then parked it due to extensive mechanical issues. Life and family kept Garry's mind away from Studebakers until his brother once again interested him in fascinating world of Studebakers when he bought a 1957 Golden Hawk. Once retirement was on the horizon, Garry decided what better time to own a Studebaker and be able to care and drive his very own, so he rejoined the SDC and joined the GCSC and in spring of 2017 he purchased Blue Goose, a 1952 Commander Starlight Coupe. (Goose was previously owned by GCSC founding member, Curt Davis.)

Outside of loving to drive his Starlight Coupe, Garry enjoys spending time with his daughter and 6-year-old grandson. Garry also enjoys reading, riding his bicycle, backpacking and, of course, working on Blue Goose.

"Wish I could have a few more Studebakers, ... They made so many great cars".

ON THE ROAD

Participating in the **Route 66 Fun Run** in early May were Ed & Linda Smith, each driving Studebakers, Ed the 1951 Stakebed, Linda the 1959 Lark SW; Ken & Arlene West, 1966 Daytona; Ken Michael, 1962 GT Hawk; Bob & Mimi Halgren, 1937 Coupe; John & Marisa Drake, an Avanti; Tony & Kellie Lapore, 1955 President sedan. Other Studebakers sighted were a couple each of GT Hawks and Avantis.

Attending the **La Palma** event in late May as vendors were John Kroulik, Mike Lynch and Russ and Sharon Ware. Showing their 1959 Lark SW were Ed and Linda Smith. Also seen at this annual event in Anaheim were Sebastian Scopelitte and Bob & Mimi Halgren.

Photos of La Palma are on the Chapter's Facebook page.

LIBERTY WILDLIFE

“Our mission is to nurture the nature of Arizona through wildlife rehabilitation, natural history education and conservation services to the community.” - *Liberty Wildlife*

Saturday, May 11th, members of the Grand Canyon State Chapter visited Liberty Wildlife along the Rio Salado to learn how this wildlife rescue and rehabilitation center accomplishes its mission. Founded in 1981 by Dr. Kathy Orr, a local veterinarian, the center was originally housed on 1.5 acres of her own backyard. The facility at 2600 E. Elwood St. opened in 2016 and sits on 6.5 acres of reclaimed land. The building itself was built with reclaimed snow fence from Montana and is a net zero building thanks to SRP who donated the solar panels. A water catchment system using cisterns was added to capture rainwater to reuse for the landscaping.

Half of the building is used as a medical wing and is not open to the public; however, observation windows allow visitors to see the volunteer medical staff tend to the many animals brought to the center. In 2016, they took in over 6,500 injured and orphaned wild animals ranging from hummingbirds to cottontails to bobcats to eagles.

The other half is the education wing which includes classrooms and an interactive laboratory. Outside are animal enclosures, an aviary, a riparian wetland and an amphitheater. It was at the theater a docent presented a pair of Indian Runner ducks who had been rescued from a backyard. The staff gave them humorous names, Cheese and Quackers, to match their entertaining personalities. The ducks eat meal worms and there was a fun demonstration between humans and the ducks to see who could gather worms the fastest. Preston Eastburn took part in this activity and he proved to be quick at gathering worms.

Then, another docent brought out Laddie, a bald eagle who is non-releasable and is part of the education program. We learned eagles are water birds and require fish for food for the calcium they provide. There were several bald and golden eagles in the animal enclosures along with many varieties of hawks, owls and other birds.

When we arrived the parking lot was full so Chapter members parked their Studebakers across the street allowing the public to see a nice display of our vehicles. Peggy and Michell set up a table with donuts, muffins and coffee which was appreciated. Thank you for the treats. Michell reminded members of upcoming events and had a Studebaker drivers drawing for some nice Meguairs products which was won by Bill Eastburn.

Attending were Michell Eastburn, 1951 Champion; George Gezelius, 1951 Champion; Garry Klinger, 1952 Commander SLC; Carl Reid, 1963 GT Hawk; Bill & Peggy Eastburn, Champ pickup; Chris & Rachel Eastburn and Chloe, Aubrey and Preston, 1963 Lark; John & Kim Rodhouse and Callan and Ainsley, 1950 2R5; Camille Mills & Paul Miller, bullet nose Olds; and Chuck and Chris Collins driving a brand X.

To learn more about this fabulous facility visit <http://libertywildlife.org/> Photos courtesy of Michell Eastburn.



Laddie

A member of the Arizona Game and Fish transported Laddie to Liberty Wildlife in early 2013 with a wing injury. The nest watchers who had been assigned to Laddie's nest, reported that the adult Bald Eagles had chased a Golden Eagle from their nesting area. However, the intruder circled around and grabbed the 4-week-old Laddie from the nest but could not carry her and dropped her through the nest tree. In the fall, Laddie's left radius was broken and the ulna suffered approximately 15 breaks. The wing was pinned and splinted. The bones mended extremely well, however, Laddie suffered some nerve damage to the wing and the feathers grew in leaving a gap in the wing, both which limited her flight ability. With her non-releasable status, Laddie became a valuable part of Liberty's education program.



For all of you who are colorists see page 16 for a picture of one of the many animals at Liberty Wildlife. Print and enjoy practicing your coloring skills.



GRAND CANYON STATE CHAPTER CALENDAR OF EVENTS

- JUNE 9** GCSC BOARD AND OFFICERS MEET AT DEER VALLEY AIRPORT RESTAURANT, 7TH AVE. & DEER VALLEY RD., PHOENIX, 1:00 PM. MEMBERS WELCOME. INFO: PEGGY AT 623-936-6116 / peggyeastburn@hotmail.com
- JUNE 15** CHAPTER FATHER'S DAY BREAKFAST AT STREETSIDE CLASSICS, 614 E. AUTO CENTER DR., SUITE 101, MESA. ARRIVE AROUND 8:30 AM FOR A STUDEBAKER DISPLAY IN THE PARKING LOT; A CONTINENTAL BREAKFAST WILL BE SERVED AROUND 9:00 AM. THERE WILL BE A CHAPTER MEETING FOLLOWED WITH A PRESENTATION BY A COLLECTOR CAR INSURANCE AGENT. INFO: peggyeastburn@hotmail.com / 623-936-6116 DIRECTIONS ON PAGE 6.
- JULY 4** FABULOUS PHOENIX 4TH FESTIVAL & FIREWORKS. CLASSIC AND ANTIQUE CAR ENTHUSIASTS ARE INVITED TO DISPLAY THEIR CARS DURING THE FESTIVIES AT STEELE INDIAN SCHOOL PARK, PHOENIX. PLEASE READ LETTER FROM CITY OF PHOENIX ON PAGE 8 AND SEE APPLICATION ON PAGE 13. TO PARTICIPATE YOU MUST PRE-REGISTER AND BE APPROVED SO DO THAT ASAP. INFO: TAMMY AT 602-534-8659
- JULY 12** THE SEMA ACTION NETWORK (SAN) ANNOUNCED THAT THE COLLECTOR CAR APPRECIATION DAY WILL BE OFFICIALLY CELEBRATED ON JULY 12. THE DATE MARKS THE TENTH CONSECUTIVE COMMEMORATION IN WHAT IS NOW AN ANNUAL EVENT TO RAISE AWARENESS OF THE VITAL ROLE AUTOMOTIVE RESTORATION AND COLLECTION PLAYS IN AMERICAN SOCIETY.
- JULY 13** CHAPTER WILL MEET AT ORGAN STOP FOR PIZZA AND GREAT MUSIC FROM THE MIGHTY WURLITZER AT 4:00 PM. BRING CASH. NO CREDIT CARDS ACCEPTED. ATM AVAILABLE. THIS IS AN EXCELLENT ACTIVITY TO INVITE FAMILY AND FRIENDS. INFO: peggyeastburn@hotmail.com / 623-936-6116
- SEPTEMBER 11-14** 55TH SDC INTERNATIONAL MEET IN MANSFIELD, OHIO AT THE RICHLAND COUNTY FAIRGROUNDS. REVIEW THE 6 PAGE SPREAD IN THE MAY *TURNING WHEELS*. QUESTIONS: DAVE HAMBLIN AT 419-947-1360 / daveh2949@centurylink.net
- SEPTEMBER 14** INTERNATIONAL DRIVE YOUR STUDEBAKER DAY AT MIXTECA'S, 67TH AVE. & BELL RD., PHOENIX FOR A CRUISE-IN AND DINING. MORE INFO TO FOLLOW. 623-936-6116 / peggyeastburn@hotmail.com
- SEPTEMBER 27-29** PACIFIC SOUTHWEST ZONE MEET IN SACRAMENTO AT THE LIONS GATE HOTEL. \$89 PER NIGHT W/BREAKFAST AND PET FRIENDLY \$50 FOR ENTIRE STAY. 916-426-9593. MENTION STUDEBAKER CAR CLUB PRICING. CALL CHAIRPERSON LINDA BARNARD AT 916-213-8989 FOR INFORMATION. SEE PAGE 14 FOR REGISTRATION FORM.
- OCTOBER 12** COOKIES WITH THE COWS. TOUR OF DANZEISEN CREAMERY, 63RD AVE. & BROADWAY RD., PHOENIX AND CAR SHOW IN PARKING LOT. MORE INFO TO FOLLOW OR PEGGY AT peggyeastburn@hotmail.com / 623-936-6116
- NOVEMBER 2** VISIT TO ARIZONA COMMENORATIVE AIR FORCE MUSEUM AT FALCON FIELD, MESA WITH LUNCH AND MEETING TO FOLLOW AT TOM'S BBQ, 5005 E. MCKELLIPS RD., MESA. MORE INFO: PEGGY AT peggyeastburn@hotmail.com / 623-936-6116
- DECEMBER 7** CHAPTER HOLIDAY PARTY. CONTACT PEGGY TO VOLUNTEER TO BE A TABLE HOST. peggyeastburn@hotmail.com / 623-936-6116



UPCOMING EVENTS

JUNE 9 GCSC BOARD MEETING

The Chapter board and officers will meet Sunday, at 1:00 pm at Deer Valley Airport Restaurant, 7th Ave. & Deer Valley Rd., Phoenix. All members are welcome to attend.

For more information contact Peggy at 623-936-6116 or peggyeastburn@hotmail

JUNE 15 FATHER'S DAY CELEBRATION

Join Chapter members in celebrating the Old Man and His Old Car with a car show and breakfast at Streetside Classics, 614 E. Center Dr., Suite 101, Mesa. Arrive around 8:30am for a Studebaker display in the parking lot; a continental breakfast of coffee, bagels and fruit will be served inside around 9am.

A Chapter meeting will follow and there will be a presentation by an collector car insurance agent from Jarosch Insurance who has a new product that may be of interest to many of you.

Directions to Streetside Classics are: take US 60 to Mesa Drive (Exit 180), go south about 1/4 mile and turn left (east) on Auto Center Drive. Streetside is on the left behind Berge Ford.

Streetside Classics consigns classic cars, hot rods, exotics and collectibles; there are around 200 vehicles you can view on your own.

For more information contact Peggy at 623-936-6116 or peggyeastburn@hotmail





FLAG ETIQUETTE

Many residents display U.S. flags at their homes and businesses and as Flag Day approaches, it is appropriate to give a few tips as a reminder how best to display a flag. These tips are courtesy of USFlag.org and are according to the Flag Code.

- ◆ When the flag is displayed from a staff projecting from a window, balcony or a building, the union should be at the peak of the staff.
- ◆ The flags should not be displayed on days when the weather is inclement, unless it's an all-weather flag.
- ◆ Display the flag only from sunrise to sunset, but it may be displayed at night - if illuminated.
- ◆ When the flag is lowered, no part of it should touch the ground or any other object; it should be received by waiting hands and arms.
- ◆ To store the flag, fold it neatly and ceremoniously.



June 2019

Sun	Mon	Tue	Wed	Thu	Fri	Sat
Questions? Call Chris at 602-995-2146	<i>Happy Father's Day to all of the Chapter dads.</i>					I
2	3	4	5	6 	7	8
9 Board Meeting	10 	11	12	13		15 Chapter Gathering
16 FATHER'S DAY	17	18	19	20	21 First Day of Summer	22 
23 30	24	25	26 	27	28	29



2020 PSW Zone Meet Update

By Larry Vahe,
Meet Chairman

As many of you now know we have selected the Sheraton Crescent Hotel at I-17 and Dunlap, Phoenix as the site of the 2020 Pacific Southwest Zone Meet to be held October 9-11. This site meets all the criteria we set forth: One site for the hotel, car show and banquet. The hotel is centrally located and we have a large parking area to be roped off for the car show.

Now that the site has been located and a contract signed your committee is now focused on having a great display to promote the 2020 zone meet at the zone meet in Sacramento this September. This will be our best shot at having a display that will attract members from the northern part of the zone.

Moving forward from there we are planning to hold a joint meeting of all the chairs associated with the zone meet sometime in October to be held at the Sheraton Crescent so you will be able to see the property and start to coordinate your event.

At the Christmas celebration we will recruit chapter members to help flesh out the committees starting to prepare for the meet itself. Other things the committee is working on is having a really great Friday night event. A number of tours are in the works for Friday and perhaps one for Sunday. A logo has been selected from all those submitted and we hope to have some T-shirts printed in the very near future.

Many, many thanks to all the members of the GCSC, SDC for recommending meet sites and submitting logos; we really do appreciate the response from the club! And thanks to all the committee members for their hard work and monthly meetings to bring this all together! If you have any questions please contact me, Larry Vahe, at 480-694-3899 or email at 58pkhawk@cablone.net

CHAIRMEN/WOMEN NEEDED

Larry mentions a meeting of committee chairmen for the 2020 zone meet in October. Many positions are already filled by Chapter volunteers but there are still three committees that are in need of a chair. They are Goody Bags, Raffles/Silent Auction and Signage. If you are interested in helping out by heading up a committee please contact Larry at either his phone or email above.

THE
Studebaker
DRIVERS CLUB INC.



CELEBRATE!

June Birthdays

- | | | | |
|----|-----------------|----|--------------------|
| 2 | Lou Fencil | 23 | Charley Haverstick |
| 4 | Jon Carter | 23 | John Rodhouse |
| 6 | Ed Costell | 25 | Mimi Halgren |
| 6 | Jerry Day | 25 | Carol Vahe |
| 7 | June Kaiser | 26 | Bill Barker |
| 8 | Jim Nereau | 27 | Sid Rosen (80th!) |
| 12 | Peggy Eastburn | 27 | Jere Tudor |
| 17 | Kent Vandenberg | 29 | Larry Swanson |
| 18 | Jim Lawrence | | |
| 19 | Paul Miller | | |
| 21 | Richard Dormois | | |
| 22 | Pete Bell | | |



June Anniversaries

- | | |
|----|-----------------------------|
| 1 | John & Linda Zimmerman |
| 2 | Jim & Jaclyn Parise |
| 3 | Chester & Nancy Bradfield |
| 3 | Jerry & June Kaiser |
| 3 | Butch & Laura Summers |
| 3 | Sam Powell & Lenka Hospodka |
| 6 | Mike & Mary Barany |
| 7 | Chuck & Chris Collins |
| 8 | Norman & Janice Marineau |
| 8 | Buddy & Elaine Wright |
| 12 | Joe & Glenda Bailey |
| 16 | Mike & Lisa Lynch |
| 19 | Larry & Carol Vahe |
| 21 | Brian & Pam Bosshart |
| 22 | Bob & Mimi Halgren |
| 22 | Tim & Julie Watson |
| 25 | Richard & Linda Hertline |
| 26 | Ted & Jan Widhalm |
| 28 | Dave & Jean Kinkel |

Children's Birthdays

D.B. Willis
(son of Eric & Amanda)



Web Sites of Interest

<https://tinyurl.com/y38jplp4>
Do Young People Still Love Cars?
Yes, Says a New SEMA Report—Just Differently

<https://tinyurl.com/yxhhdayf>
Video of the construction of Stewart Motors and a parade taking place in front of the dealership. Get your Studebaker fix. Thanks to Garry Klinger for the link.

<https://tinyurl.com/y2xqfqx4> Hemmings article about the Franklin Museum in Tucson.

Fabulous Phoenix 4th Festival & Fireworks Thursday, July 4, 2019 – Steele Indian School Park

Dear Antique & Classic Vehicle Enthusiasts,

Celebrate Independence Day at the annual Phoenix Fourth coming to Steele Indian School Park on Thursday, July 4th, 2019! This free non-alcohol family evening event features live music, fun children's activities, food and beverage vendors, an antique and classic vehicle exhibit including military vehicles, fantastic fireworks and more!

If you have an antique, classic or military vehicle you would like to exhibit **please fill out and send the attached vehicle exhibitor registration application ASAP** for review approval to: Tammy Parker, c/o City of Phoenix Parks and Recreation Department, Downtown Division Park Office, 2700 N. 15th Ave., Phoenix, AZ 85007 - or by email tammy.parker@phoenix.gov

No cost to exhibit a vehicle, but by free pre-registration and approval only.

Do keep in mind when submitting an exhibit registration application and if your vehicle is chosen, for event logistics and visitor safety (est. at 100,000+ people), all approved exhibit vehicles will need to arrive by 4:30pm and stay until the event's conclusion after 10pm unless it is a true emergency.

Actual public events hours are 6pm to 10pm (fireworks at approximately 9:30pm).

Non-approved exhibit vehicles will not be allowed event day entry.

We look forward to hearing from you.

Thank you and happy motoring!

Tammy Parker, 602-534-8659

City of Phoenix Parks and Recreation Department

tammy.parker@phoenix.gov

See page 13 for application with more information.



A thank you was received from the Heart of Ohio Chapter for our Chapter's donation for awards at the International SDC Meet in September.

Turning Wheels

As SDC members most of us receive *Turning Wheels* magazine and while it's hard to give up even one precious issue, there usually comes a time when we can no longer keep this treasure trove and we ask ourselves what to do now.

One solution is to give them to a new member whose turn it is to soak up all that Studebaker culture but if that is not possible then consider this solution suggested by a member on the SDC forum. First, keep all the issues that have your favorite feature articles, then put the rest in the trunk of your Studebaker. When you attend a car show or cruise-in hang a "Free Studebaker Magazine" sign and watch them disappear. Perhaps a young show goer will pick up one or more issues leading to interest in our beloved Studebaker marque.

NUTS AND BOLTS – A few tidbits on threaded fasteners –

By Studebaker Mike (Reprinted from *Hawk Talks*, newsletter of the Karel Staple Chapter, SDC.)

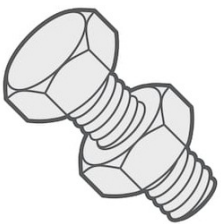

Grades of steel bolts: Steel bolts come in different strengths; the most popular are grades 2, 5 and 8. The heads of the bolts should have markings on them indicating which grade of bolt. There are generally equally spaced radial lines. A grade 2 bolt will have no markings on the head of the bolt. A grade 5 will have 3 radial lines and a grade 8 will have 5 lines. I do not keep Grade 2 bolts in my shop. I believe they are too weak of a fastener and if accidentally got used where a grade 5 or 8 bolt is required the chances of failure is high. A grade 5 bolt is good all around and fits most applications. Grade 8 are stronger, they are hardened and used in unique or special applications. One feature between a grade 5 and 8 bolt is a grade 5 will bend before it breaks; an 8 will snap/break before it bends.

Stainless bolts are great in some applications and terrible for others. The two most popular materials are 316 and 304 alloys. 316 has no iron in the alloy, it won't rust or stain, polishes up nice and is great for show. 304 has a little iron in its alloy causing the bolt to show a little staining on the surface and is a little stronger than 316. Need a stainless bolt to function, use a 304; need it to show, a 316. Both these bolts are weaker than a grade 5 bolt. Don't ever use a stainless bolt for an electrical connection. The hotter stainless gets the more it impedes the flow of electricity. Example, your battery ground cable to the engine block.

Coating bolt threads: Rarely do I ever install a bolt with dry threads. I've had to remove a number of fasteners using the appropriate expletive to get them out and some of them were mine that I installed a long time ago. Don't be afraid to put a little something on bolt threads - engine oil, grease, anti seize (my favorite). For electrical connections use D-Electric (silicone grease) this product doesn't conduct electricity or impede the flow of electricity.

Bolts get over looked, give them some attention. After all, without them our Studebakers would all be in pieces.

A BRIEF HISTORY OF STUDEBAKER DISC BRAKES

By Keith Graham

Le Mans, France, 1953, Jaguar stuns the racing world finishing first, second and fourth in the famed Le Mans 24 Hour Endurance Run. Three "C-Type" Jaguars were able to decelerate from 150 mph to cornering speeds, averaging 105.83 mph for 24 hours breaking the 100 mph track average speed barrier for the first time. Amongst their secrets: Dunlop caliper disc brakes.

August 1962, Studebaker stuns the U.S. auto industry announcing (drum roll, please) Bendix caliper disc brakes are available on all models! Licensed to Bendix by Dunlop of England, these brakes featured a fixed two-piston caliper with pad retractors to eliminate drag, and 11.5 inch diameter solid rotors, the very same brakes as the Le Mans Jaguars used.

A decade earlier, January 22, 1951, Henry James Butler of Dunlop Tire and Rubber Co. LTD, filed for a U.S. patent on "an invention described as relating to disc brake assemblies for motor vehicles" (paraphrased). April 30, 1957 Patent #2,790,516 was granted to Dunlop. Mr. Butler was granted several other patents as well for disc brakes over a period of years. During 1956 Bendix Corp. of South Bend, Indiana acquired exclusive manufacturing rights for these brakes in the U.S.

With Studebaker's new high performance grand touring coupe, the Avanti, being readied for production in 1961, it was a natural that president Sherwood Egbert would want the best possible brakes for his brainchild. An avid pilot and sports car enthusiast, he was no doubt familiar with disc brakes, plus Bendix the only U.S. manufacturer was in hometown South Bend.

Featuring a suspended (firewall mounted) dual-diaphragm Bendix "Master Vac" on Larks and Avantis and a remotely mounted "Hydrovac" on Hawks, a single chamber master cylinder was used on all. A proper braking force ration of 62% front and 38% rear was achieved with large 11 inch diameter rear drums, 2 inches wide and small 3/4 inch bore wheel cylinders. Described by Studebaker as "self-centering" and Bendix as "non-servo", these non self-energizing drum brakes allowed the more powerful calipers to bear the brunt of the heavier front stopping demands.

Interestingly, the caliper cylinder fluid steel lines used English-type flare fittings, and no proportion or combination valve was used for fluid distribution. AMC used the same rear drum brakes on their 1965-'66 Marlins equipped with Kelsey Hayes front disc brakes. Chrysler used a similar version of the same Bendix Master-Vac design on 1968-'70 Chargers, Roadrunners, Super Bees, etc. Many British sport cars also used the Dunlop disc brakes, as well as Datsun (Nissan) sports cars and I believe a Toyota model, as well.

It has been asked why not four wheel discs? There is a photo of an Avanti mock-up with independent rear suspension and rear calipers. But I think the reason it never happened was there was no provision for mounting an emergency brake mechanism.

On the Dunlop design English cars used transmission mounted e-brakes where American cars (except various years of Chrysler products) used the rear drums activated by cables instead. Simply put, there wasn't enough time or money to develop new rear calipers with e-brakes, in my humble opinion.

These brakes were simple, durable and stopped quite well. They do, however, require some specialized knowledge to service them. I've had several Studes (and still do) with them and no problems. That's it!

Disc Brake Caliper Components

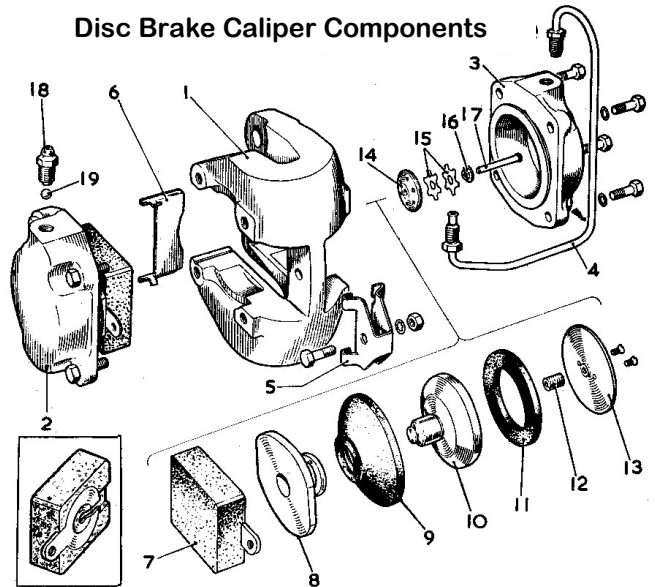

The disk brake caliper components

- 1. Caliper
- 2. Cylinder block
- 3. Cylinder block
- 4. Bridge pipe
- 5. Keep plate
- 6. Support plate
- 7. Friction pad assembly
- 8. Packing plate
- 9. Dust seal
- 10. Piston
- 11. Piston seal
- 12. Retractor bush
- 13. Plate
- 14. Cap
- 15. Spring washer
- 16. Retractor stop bush
- 17. Retractor pin
- 18. Bleed screw
- 19. Bleed screw ball

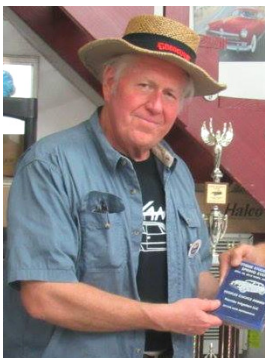

Keith owns many fine Studebakers, including this rare 1963 Lark Skytop shown at the right which he displayed at a Chapter event at the Pavilions.

In the photo on the left Keith is accepting a People's Choice award for his 1963 Lark, "Casper", at the Antique Studebaker Spring Event in 2018.

Photos courtesy of Linda Smith. Illustration courtesy of Bob Johnstone's Studebaker Resource Website.



MAGAZINE SUBSCRIPTION SERVICE
 Business By The "Golden Rule" Since 1965
(623) 581-6611
 Richie & Dolores Fein
 1437 W. Rosemonte Drive • Phoenix, Arizona 85027

1/20



Junkyard Jonny LLC

Jonathan Carter
 Proprietor
 Studebaker, Fiat, AMC
 Car and Parts Sales

480-577-5764
 joncarter@cox.net

1/20

Keri Baker DESIGNATED BROKER
 PROPERTY MANAGER



2432 W. PEORIA AVE. #1044
 PHOENIX, AZ 85029

623-688-5844 OFFICE
 623-738-0464 FAX

KERI@PARAMOUNTPMR.COM
 WWW.PARAMOUNTPMR.COM

YOUR PARTNER FOR SUCCESS

6/19

Studebaker Parts

Need Glass and Rubber? Call Russ for a quote.

Russ & Sharon Ware
 2700 E. Magnolia Dr.
 Gilbert, AZ 85298
 602-995-5311
 E-mail: Russ@studebakerparts.com



Visit the store at <http://www.studebakerparts.com>

12/19

John Ershler Raul Reyes



ASE CERTIFIED PROFESSIONALS
 DOMESTIC / FOREIGN AUTO REPAIR

2526 W. Northern Phoenix, Arizona 85051

(602) 841-1440
 Se habla español

6/20

Arizona Contractor's License
 Residential & Commercial

Installation & Repair
 premierirrigation.org



Office: 623-337-5294
 Fax: 623-337-5301

CHRIS EASTBURN
 Cell: 602-380-1439

14211 W. Windrose Dr, Surprise, AZ 85379

- COMPLETE REPAIRS
- EMISSION REPAIRS
- MACHINE WORK & WELDING

KANE'S AUTOMOTIVE

8743 N. 78th AVE • (One Block S. of Olive) • PEORIA, AZ 85345
 623-878-2077 • Fax: 623-979-0355



Jim Eddie Robert

5/20

SCHOLARSHIPS AVAILABLE

The Studebaker National Foundation has \$1,500.00 scholarships available for qualified students. Please visit <http://www.studebakernationalfoundation.org> to download an application.

You can also contact Brian Millette at 602-300-5313 or abmillette@cox.net if you have questions about the SNF scholarship program.



Don't forget to have a fire extinguisher in your Studebaker to place near the left front tire at activities where you show your Studebaker.



INTERNATIONAL
DRIVE YOUR STUDEBAKER DAY
 ON THE ROAD AROUND THE WORLD



—SECOND SATURDAY IN SEPTEMBER—

FOR SALE - STUDEBAKER CARS, TRUCKS AND PARTS - WANTED

TO PLACE OR CANCEL AN AD: Please contact Chuck Collins by phone at 602-995-2146 or e-mail ccollinsaz@cox.net or write 2410 W. Freeway Lane, Phoenix, AZ 85021-4135.

Ads for members are free. Business card ads are \$25 per year. Ads not updated every 4 issues will be dropped.

STUDEBAKERS FOR SALE

1955 C-Cab Pickup. Chevrolet Vortec 350 engine. 700 R4 Trans. Dodge front suspension. Ford rear axle. Needs paint repair. Contact Elaine Savage in Flagstaff at 928-607-3079. (2)

1946 Champion Sedan. Stored outside for many years. **1928 Studebaker 6 cylinder engine with transmission** on stand, stored inside near 1-17 & Northern. Call Karen at 602-841-1056. Mention Studebaker. (2)

1951 4dr V8 Automatic, partially apart; paint stripped. Rollable \$1500, 928-713-5520, leave message. (0)

1963 R1 Avanti 63R2788 in near perfection condition inside and out. Restored to stock by Allen Barth of the Studebaker Garage in Herrington, WA. Engine rebuild included lowering compression, AC, HD springs, PW, PS, PB, AT, Twin Traction. Upgrades include exhaust system, carburetor, AC compressor, alternator, 5-blade radiator fan, interior double insulation. Factory and previous owners documentation, calendar featuring car, car cover. Original AC compressor, carburetor, radiator fan and several years of Avanti Magazine included. \$39,500. Contact Tim Painter for pictures at paintim613@aol.com / 928-580-0226

1941 Commander. 4-Door, two-tone lime and green good paint, new interior, radial tires with less than 5,000 miles, strong Commander engine, no smoke, great brakes, hill holder, overdrive transmission, fog lights, extra chrome deco, radio, clock, seat belts, directional signals, floor mats, \$18,500 Gary Keating 480-209-8279 (0)

Many Studebakers and parts available for sale in Maple Plain, MN. The cars and some parts are listed on www.classiccarsleftbehind.com We have lots of parts that haven't been priced or inventoried yet. Smaller parts are being listed on eBay under the id: wendyjasmine Wendy Marple 612-709-0143 wsmarple@gmail.com (1)

STUDEBAKER PARTS FOR SALE

Left and right lower quarter repair panels for a 1953 up "C" or "K" body \$150 each. **Fat Man Mustang II front suspension** for a 1953 up "C" or "K" body car, complete with control arms, spindles, and springs. Rack and pinion not included. \$2,000.00 Jim at jimraynovic@earthlink.net 480-734-1800 (3)

Studebaker V8 engine overhaul gasket sets, Felpro 7669 S1 & S2, for 224, 259 & 289 cars-trucks & 1957-58 Packards. \$75 each **Studebaker V8 oil pan gaskets** #1559368 & 1561465 \$25 each all 4 gasket sets for \$175 OBO. Thanks. Fred 520-883-7418 email nora.gooch@yahoo.com (3)

1941 Commander 6 engine, totally rebuilt by Ken Michael and test stand break-in, ready for installation. **1941 Commander 6 engine** ready for rebuild. Call for price.

2 – 1941 4-Door Commander car bodies with good front fenders and hoods, good frames, rear ends and drive shafts, Payson area location. They will roll but need tires. Bring your trailer with winch. They are FREE, no charge. Gary Keating 480-209-8279 (0)

Complete running 259 \$300.00. '61 Hawk hood good condition, \$200.

'56 Golden Hawk left side fiberglass fin \$100. '61 Hawk steering box \$100. GT Hawk headliner bows, very nice \$75. for full set. Parting out '56 1/2 ton C-Cab truck. Let me know what you need. Studebaker 1/2 ton brake drums \$50.ea. Studebaker V8 Valley pans \$5.ea.2R5 truck Champ 6 bellhousing \$40. '39 right side grill has been re chromed \$300. '51 Commander left front door \$45. '51 Commander right rear door \$45. '56-'61 Hawk grill excellent chrome \$100. GT Hawk front bumper \$40. GT Hawk rear bumper \$40. '62 Lark grill \$50.00 very nice Center link for power steering \$25. '53 sedan trunk lid \$40. '62 GT Hawk grill \$50. '62-'64 GT Hawk complete set good glass in chrome frames: wing windows, side glass and back windshield. Hawk and coupe center pan for bucket seats and mounting for console, \$40. '59-'60 Lark or '60-'64 Champ truck hood \$50. '59-'60 Lark trunk lid, \$35.00 good condition '60-'64 Champ truck left door \$50. ea. '62 Lark Station Wagon upper tailgate \$50. '62 GT Hawk rear valance that is between bumper and body \$40. '62 Lark rear quarters \$75. for both or \$40.00 each no rust '63 Lark 4 door front doors \$50. ea. '63 Lark rear doors for Wagonaire or 4-dr sedan \$35. ea. Lots of other parts, if you don't see what you want, call me. I may have it. Large items for pick up, email for pictures. Email for pictures. Jerry at 520-979-0065 or studeblu@gmail.com (0)

CHAPTER FUNDRAISING

Tshirts featuring the Studebaker script, a bullet nose car, a trio of saguaros and a buzzard are available for \$15.00 and can be ordered in various colors. If you wish to order one for yourself or for kids please see Peggy Eastburn at any meeting or event or contact her at peggyeastburn@hotmail.com / 623-936-6116

PRESIDENTIAL CHAMPIONESTOGAISTARLINEERIGHTHAWKIDAYTONAIRESKINEISLIVERHAWK

C R U I S E R I A V A N T I C O M M A N D E R I R O C K N E I E M F I P H A E T O N I S T A R L I G H T I S K Y W A Y I W A G O N A I R E

The *ECHO*

Newsletter of the Grand Canyon State Chapter, SDC
 P.O. Box 37464
 Phoenix, AZ 85069-7464

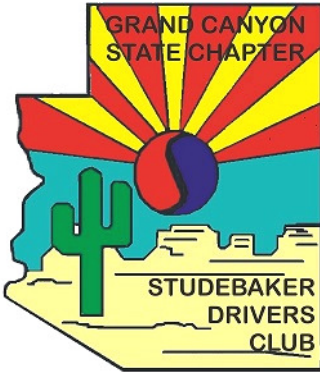

REMINDERS FOR JUNE

- 9 Board Meeting - DV Airport Restaurant
 - 15 Father's Day Breakfast at Streetside Classics
- See pages 5 and 6 for details.

*Exciting new 1953 Studebaker
 receives Fashion Academy Award!*



1953 STUDEBAKER

Gold medal for outstanding design and distinctive styling presented to the new American car with the European look

Four directors of Fashion Academy, the famed New York school of fashion design, have awarded Studebaker their 1953 gold medal for style and design. Leading authorities on car styling join with motorists everywhere in acclaiming the 1953 Studebaker's distinction. "There can be no question about it," reports Motor World, "Studebaker has, with its new model, made every other American car look ten years older."

Own this Fashion Academy Award beauty yourself—an excitingly different new Studebaker sedan, coupe or hardtop—a Champion in the lowest price field—or a brilliantly powered Commander V-8. Arrange to drive this dramatically distinctive new American car with the low-slung European look—the car that officially proved itself a gasoline mileage star in this year's MobilGas Economy Run. Order your new 1953 Studebaker right away.



Visit the Chapter web site at
<http://www.grandcanyonsdc.com>

Scan the QR code with your smart phone to visit the chapter web site. Need a scanner? Search for "QR Scanner" in your app store.



Visit the chapter on Facebook at
 Studebakers Grand Canyon State Chapter

GRAND CANYON STATE CHAPTER STUDEBAKER DRIVERS CLUB MEMBERSHIP APPLICATION

All memberships are for one year beginning on January 1.

Chapter dues are (check one)

- \$18.00 yr to receive the newsletter by mail or
 - \$15.00 yr to receive the newsletter electronically
- If joining during the year, dues are prorated at \$1.50 per month.

Your dues include eleven issues of the award winning *ECHO*, a Chapter roster and the best club activities throughout the year.

Membership in the Studebaker Drivers Club, Inc. is compulsory to be a member of the Grand Canyon State Chapter of SDC, Inc. **If you are not a member of SDC, add SDC dues to your chapter dues** which the treasurer will remit for you. SDC dues are \$24.00 for new members, first year only. To renew your SDC membership, add \$31.00; both include *Turning Wheels* magazine. Or \$10.00 for membership without the magazine.

Any questions can be directed to the address below or to Chris Collins at 602-995-2146 or ccollinsaz@cox.net Please make check payable to the Grand Canyon State Chapter, SDC and send with this form to: GCSC, P. O. Box 37464 Phoenix, AZ 85069-7464.

Name _____ Spouse _____

Address _____

City _____

State _____ Zip _____

Telephone # _____

Cell # _____

E-mail address _____

SDC Membership # (Required) _____

Expiration date _____
 (May be found on your SDC membership card.)

of Children under 18 years of age _____
 (List name(s) and birthday(s) on back.)

Birthday (Month & Day) Self _____
 Spouse _____ Anniversary _____

Studebakers You Own: _____

New Member? _____ Referred by _____



2019 Fabulous Phoenix 4th • Exhibit Vehicle Area Application Thursday, July 4, 2019 • Steele Indian School Park

Thank you for your interest in participating! Please fill out the information below and send ASAP for review and possible approval to:

Tammy Parker, c/o City of Phoenix Parks and Recreation Department,
Downtown Division Park Office, 2700 N. 15th Ave., Phoenix, AZ 85007
or by email tammy.parker@phoenix.gov

Questions? Please call Tammy at 602-534-8659.

Name _____

Address (include city, state & zip): _____

Phone: _____ Email: _____

Antique/Classic Vehicle (make, model & year): _____

Bringing exhibit vehicle by truck &/or trailer? _____

Please include a photo of the exhibit vehicle by email or include one with this application.

Exhibit space required? _____

Deadline to submit vehicle exhibit application - June 21, 2019

Please remember this is a volunteer program:

After receipt & APPROVAL of this application, confirmation will be made by phone/email.

Approved vehicle exhibitors will receive their required exhibit parking entry passes w/map of their space location 1 week prior to event. Please be on the look out for them in the postal mail. Non-approved vehicles will not be allowed event day entry.

SET UP

Approved exhibit vehicles may load in on July 4th beginning at 3PM. All vehicles must be in their assigned space by 4:30PM. Should your set up require additional time, please arrange with event area coordinator in advance.

TAKE DOWN

No exhibit vehicle may depart from the event site before 10:00PM unless there is a true emergency and the event area coordinator has been contacted. No exiting the Car Display Area until the area is cleared of crowd and foot traffic - this process may take up to 45 minutes. Please be patient.

ALL VEHICLES MUST EXIT IN A SAFE AND TIMELY MANNER AFTER THE EVENT.

Event Location: Phoenix's Steele Indian School Park at Central & Indian School Rd.

The City of Phoenix prohibits discrimination on the basis of race, color, religion, sex, national origin, marital status, sexual orientation, gender identity or expression, or disability in its services, programs and activities.

Pacific Southwest Zone Meet September 26-29, 2019

The Karel Staple Chapter SDC will be hosting the 2019 Pacific Southwest Zone Meet in Sacramento, CA. The meet is open to all Studebakers, Packards, Pierce Arrow and EMF.

Host Hotel: Wyndham Lions Gate Hotel; 3410 Westover Street, Sacramento, CA 95652; (916) 426-9593 Ext #3. Room rates are \$89.00 plus tax/fees per night. Pets are welcome for \$50 for entire stay. Please state that you are with the "Studebaker Car Club" to receive this discounted price. Hotel guests will receive a complimentary breakfast and in-room internet access. (after Sept. 17th, rooms are available on an "as available" basis). Dry RV parking is \$25 night.

Judging: All registered cars will have secure parking in our parking area. Cars will not be judged on the standard point system. A team of judges will judge all registered vehicles. There will also be a People's Choice and Chapter Choice award. Trophies will be awarded at the Saturday night awards banquet.

Activities: Thursday: is open tour day. There are \$8 discounted tickets for the California Auto Museum, Air Museum and Sacramento Zoo. Tickets may be purchases at the venue with Zone Meet Badge. Also, park with the Planes at the Aerospace Museum from 9 - 2. Friday: Welcome Meet & Greet Friday Dinner at 5:00 at the Hotel. Saturday: Car show during the day and Awards Banquet and presentation. We will have a raffle both days and valve cover races on Saturday (trophies for the winners).

General Registration:

Name _____ Guest _____

Mailing address _____

Email for registration confirmation _____ Phone _____

SDC No. _____ Chapter Affiliation _____

Registration per family: \$35.00 _____ Postmark after Sept 17th \$40.00 _____ Friday night Meet & Greet: No. _____ N/C (maximum 2 dinners per registration) add'1 Fri Night dinner No. _____ x \$16 _____ Awards Banquet: Beef No: _____ x \$40 _____ Chicken No: _____ x \$40 _____ Vegetarian No: _____ x \$40 _____ Judged vehicle : No: _____ x \$15 _____ Stude Yr/Model _____ Display only: No: _____ x \$10 _____ Stude Yr/Model _____ Car Corral (for sale) No: _____ x \$10 _____ Subtotal A: \$ _____	Vendor Outside Table No: _____ x \$20 _____ Valve Cover Races No: _____ N/C Memorabilia Space No: _____ N/C Men's T-Shirt: S__ M__ L__ XL__ No: _____ x \$15 _____ 2XL__ 3XL__ No: _____ x \$19 _____ Women's V-neck Tee: S__ M__ L__ XL__ No: _____ x \$15 _____ 2XL__ 3XL__ No: _____ x \$19 _____ Trophy donation: No: _____ x \$20 _____ Subtotal B: \$ _____ Total A & B: \$ _____
---	--

RETURN REGISTRATION & FEES TO: Karel Staple Chapter, SDC – c/o Johanna Smith
 2140 Coronado Avenue, Napa, CA 94559
 For more information contact: Linda Barnard (916) 213-8989 or Brian Challenger (916) 880-8877
 Email: karelstaplesdc@yahoo.com
 Website: www.hawktalks.com

Each entrant expressly agrees to indemnify SDC, the Karel Staple Chapter of SDC, the Lions Gate Hotel, their representatives and anyone else connected with the Pacific Southwest Zone Meet, from any known or unknown damages, injuries or claims that may occur on the way to, during the event or leaving the meet. I acknowledge that California State Law requires that I carry proof of current vehicle insurance and that show organizers require adherence to this law for participating vehicles. ALL ENTRIES MUST HAVE A FIRE EXTINGUISHER FOR SAFETY PURPOSES. I acknowledge that I am over the age of 18 years old and have read and understand all of the above.

Entrant's signature: _____ Date: _____